



# LEADING TECHNOLOGY FOR A BETTER FUTURE

Yutong Battery Electric Mixer Truck M610E

Yutong International Holding Co., Ltd. Tel: +86 371 8533 8999

Images may include optional devices and accessories that are not installed as per standard specifications. Yutong reserves the right to change the product specification without prior notice. All rights reserved.

Special statement: The pictures and data in this brochure are for reference only and shall not be used as the basis for ordering. The Company reserves the rights of making changes and interpretation.

All rights reserved, Infringement on copyright shall be held accountable. April 2024 edition

# YUTONG GROUP

## Full speed ahead for a top-level new energy commercial vehicle group

Yutong is a prominent commercial vehicle group specializing in buses and trucks, with a comprehensive product lineup including buses, trucks, special-purpose vehicles, sanitation equipment, and construction machinery.

Accumulated sales volume of new energy vehicle exceeded

**190,000+ units**

In 2023, the group's annual sales exceeded

**45,378+ units**

Exported to over 100 countries and regions worldwide

**100+**

In 2023 new energy buses' sales exceeded

**7,800+ units**



## Yutong Bus

Yutong bus, as the flagship division of yutong group, is a globally renowned leader in the bus industry. Its product range caters to diverse market segments, including buses, long distance coaches, tourism coaches, commuters, school buses, and special mobility.

In 2023, Yutong Bus achieved a global sales volume of 36,518 units, generating a turnover of RMB 36.23 billion and maintaining an annual production capacity of over 60,000 units. The share for its large and medium buses in global market is more than 10%. By the end of 2023, it had sold more than 180,000 new energy buses cumulatively, establishing itself as a global leader in terms of production and sales scale.

## Yutong Truck

Yutong Truck, a burgeoning sector of the Yutong Group, capitalizes on its vehicle manufacturing capabilities, industry operation capabilities, and the technical advantages of its HV system of new energy vehicles. Targeting market segments such as hauling, tipping, mixing, express delivery, ecommerce, supermarket distribution, and LTL logistics, Yutong offers a range of new energy heavy and light trucks that are energy-efficient, environmentally friendly, intelligent, safe, reliable, and built to last.

By the close of 2023, around 17,000 new energy trucks have been sold.

With the autonomous investment of RMB 1 billion, Yutong has built an engineering technology center covering an area of 163 mu (10.87 ha) and 7 national-level innovation platforms. It possesses a comprehensive verification and evaluation system that integrates components, systems, and vehicles.



# YEA

The first electric exclusive platform integrating software and hardware in the industry, opening a new era of "Hardware integration and Software over-the-air".

More economical

More durable

More convenient



# Yutong Battery Electric Mixer Truck

**Mature high voltage system  
reliable and durable**

 **Battery** ————— **94%**  
Increased energy density

 **Motor** ————— **100%**  
Increased torque density

 **Electric control** ————— **40%**  
Reduced energy consumption  
under working conditions

Driving Range Under Comprehensive Conditions:

**100KM**  **300KM**

Safe Operation: **190,000** vehicles  
**40.2** billion kilometers

Market Performance:

Ranking in market share in Chinese  
new energy bus market and European  
new energy bus market

**NO.1**



## New-Generation Super-energy Battery with High Safety

Water and fire resistant, robust in body, powerful in capacity



HIGH SAFETY	HIGH ENERGY EFFICIENCY	LONG SERVICE LIFE
"Sandwich type" fireproof structure Dry gas protection system	High specific energy cell High integrated structural design	High-strength structural design   Efficient temperature equalization   Intelligent balance
<b>1m24h</b> Utmost water resistance	<b>25%</b> Space saved	<b>400,000-800,000km</b> Service life
<b>1,300°C</b> Maximum fire protection		

## Most Integrated Power Domain Controller

Utilize every kilowatt-hour of electricity to the extreme  
Longer driving range

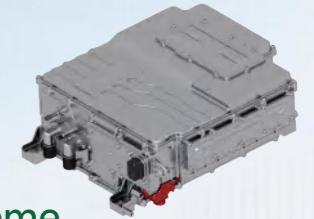

Maximum efficiency **97.5%** Reduced system weight **50%**  
Reduced energy consumption of vehicle **5%**



## NEW-GENERATION EFFICIENT AND LIGHTWEIGHT INTEGRATED E-AXLE

More capacity and efficiency for less worries

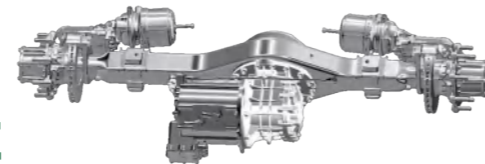

<b>49%</b> Reduced system weight	<b>30%</b> Chassis space saved	<b>93%</b> Maximum efficiency of system	<b>55%</b> Maximum braking energy recovery	<b>5%</b> Reduced energy consumption of vehicle
-------------------------------------	-----------------------------------	--	---	--

## The First Intelligent Cloud Platform With Pb-level Storage And Tera-scale Computing Power

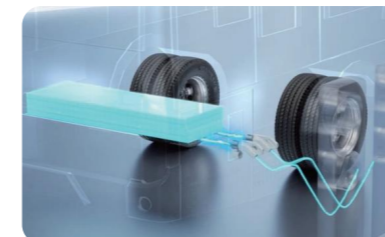

### ◎ DOUBLE GUN CHARGING Fast Charging

Easy running for A day after charging for one hour  
Current-carrying with single gun 250A  
Double quantity of charging energy  
Full compatibility  
Plug and unplug at any time

### ◎ INTELLIGENT & NETWORKED

Commercial vehicle cockpit, more convenient for commercial use

### ◎ INTELLIGENT ASSISTANT OPERATION MANAGER

**Clear at a Glance:** Multiple management data, being clear and accurate.  
**Comprehensive Management:** Comprehensive management assistant for vehicle status, driver, energy consumption, etc.  
**Customization:** Support customized development.

# Yutong Battery Electric Mixer Truck Addressing Customer Concerns With Core Technology

## FURTHER

- Super-energy battery with high safety and large capacity
- High-efficiency electric control system
- Multi-stage braking energy recovery system

Customer Cases: Comprehensive power consumption of commercial concrete transportation as low as

**1.44 kWh/km**

(Note: This power consumption is the lowest under typical working conditions in China)

## SMARTER

- Digital operation management system
- Vehicle intelligent control
- Active inspection
- Management of dangerous driving behaviors
- Traction battery safety warning

## STRONGER

- High-power permanent magnet synchronous motor
- Efficient combined braking system

## HIGHER

- Highly reliable five-in-one electric control system
- High-protection HV system (battery, motor and electric control)
- Adaptive thermal management system
- Battery safety protection system

## FASTER

- Double gun charging, fast charging
- Maintenance-free and long warranty





# Intelligent Assistant Safety and Comfort



- ① Passenger-car-style instrument panel with a black main tone and metallic bright stripes embellishment for ultimate elegance
- ② Column-shift design, reducing the driver's driving intensity and optimizing the driver cabin space
- ③ Instrument panel stitching design with delicate texture
- ④ Slightly convex middle floor, spacious interior with good trafficability

## Intelligent driver assistance

Can achieve one button start, multimedia large screen, and ASR; You can freely choose functions such as emergency assist for pedal misapplication (EAPM), collision warning, lane departure warning, etc. for safer driving.



## Creep mode

Slow moving at a low-speed creep function and automatic low-speed creep function, making the speed more stable, and easy to control in scenarios such as reversing for loading and unloading, following up, moving and parking.

## New generation airbag seat

Yutong's new generation airbag seats, dual airbags electronic control lumbar support; standard seat ventilation, heating and one button seat upward/downward functions to reduce driving fatigue; driver departure reminders for high safety.



## Breathable and comfortable sleeping berth

The sleeping berth, filled with natural coconut palm, offers excellent breathability and enhanced comfort, making it convenient for drivers to take a quick rest.



# Special mixing tank Intelligent and durable

## Tank shaking mode

The industry's first mode assists the driver to quickly change the rotation direction of the tank, effectively preventing the concrete from solidifying.

## Motor side mounted rescue

The industry's first mode assists the driver to quickly get rid of tank shutdown status caused by vehicle faults, effectively preventing the concrete from solidifying.

## Selected parts to achieve ultra-long life for the tank

Special upperstructure subframe, wear-resistant tank body mold, cold pressed formed blades  
Rollers and wheel tracks made up of modified forged steel materials  
Charging hopper, discharge hopper, and chute welded with high-strength wear-resistant plates

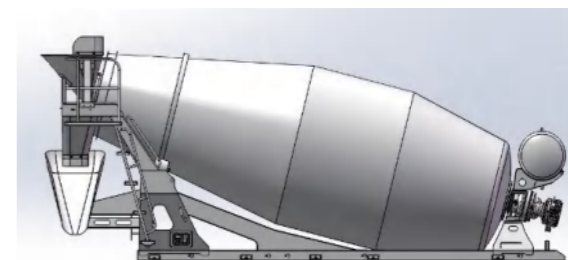
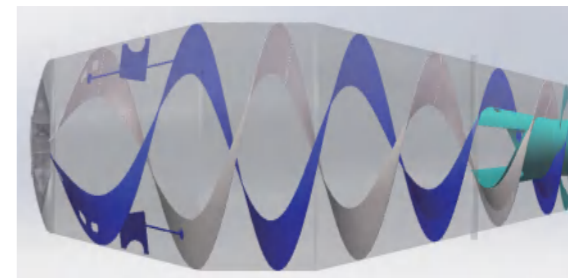

# Proven Ultra-Durability through Rigorous Reliability Testing

## The Industry's Most Stringent Reliability Testing Standards

30,000 km Reliability Verification:



High-speed loop

Climbing

Wading

## Rigorous Testing Standards for Core Components of HV system Crafting Exceptional Products



Battery collision test



Corrosion resistance



Vibration and squeeze resistance



Motor impact test

## Professional Services

Focusing on the distinct operational and service challenges faced by truck customers in different countries, Yutong provides extensive global after-sales services, setting up a first-rate specialized maintenance system for new energy vehicles in the industry.

**4**

Global distribution centers

**10**

Part distribution centers

**84**

Overseas part distributors

**325**

Secondary service outlets

**15** minute

Response to demand

**24** hour

Emergency rescue service

## Parameters

Item	Parameter	
Basic parameters	Overall dimensions (mm)	9,760×2,550×3,730
	Wheelbase (mm)	1,950+2,900+1,350
	Curb weight (kg)	14,075
	Rated torque/Maximum torque(N·m)	1,500/3,000
	Rated power/Peak power (kW)	330/450
	Charging Power(kW)/Charging time(min)	320/73
	Driving range (CHTC-D) (km)	260(Full-load 32T)
New energy configuration	Traction battery (kWh)	350, LFP battery
	Transmission	AMT
	Motor (kW)	330/450, permanent magnet synchronous motor
	Motor controller	Yutong integrated control unit (ICU)
	Vehicle control unit	Yutong five-in-one controller
Charging configuration	European standard-Double plug fast charging	
Chassis	Suspension system	Few leaf springs
	Tire	315/80R22.5
	Front axle(t)	2×5.5
	Drive axle(t)	2×11.5
	Braking system	EBS+ESC
Driver cabin configuration	Driver cabin	2.5m-wide flat roof extra cab, separate metal bumper
	Seats	Driver seat with airbag shock absorption
	Steering wheel	Multi-function steering wheel
	Dashboard	Color LCD instrument cluster
	Sleeper	Lower Bed
Electrical equipment configuration	Air conditioning system	Automatic air conditioning and heating system
	Headlamp	LED combination headlamp
Upperstructure	Stirring capacity(m <sup>3</sup> )	8
	Drive form	Motor+reducer+controller

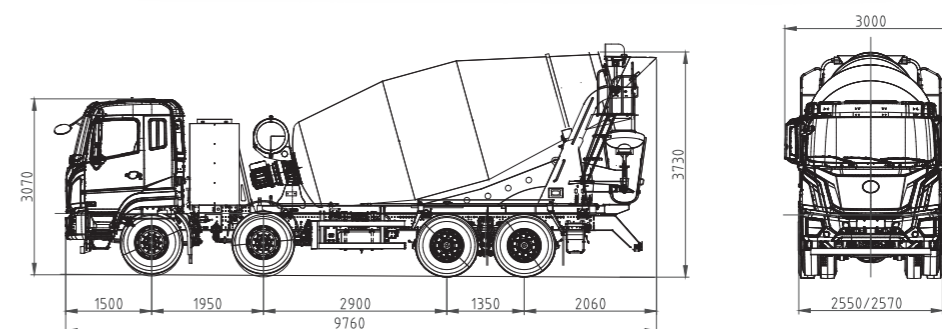

Disclaimer: this configuration table is for reference only and not used as the basis for contract negotiation. The actual vehicle shall prevail.